



*This part should only be installed by personnel who have the necessary skill, training and tools to do the job correctly and safely. Incorrect installation can result in personal injury, vehicle damage and / or loss of vehicle control.*

**Read instructions completely before beginning installation.**

**Required Tools:**

<b>Weld on option:</b>	<b>Bolt on option:</b>
• Welding equipment    • Paint    • Grinding equipment    • 1/8" Hex Key	• Drill motor and drill index

**Using the Coil Carrier / Bolt Up Mount:**

**As a Coil Carrier:** This mount can be used with coil springs when the spring inner diameter is at least 3.25" at the upper end and the spring seat is large enough and flat enough to accommodate the mount. The outer diameter of the plate for this mount is 6.25 inches, however the mount can be cut or turned down to fit smaller coil spring mounts. The coil carrier mount is sandwiched between the upper spring seat on the vehicle frame and the coil spring as shown in **FIGURE 1**. The JounceShock threads rigidly into the Coil Carrier Mount, but because the Coil Carrier is only held in place by the end of the coil spring, it effectively acts as a "flexible" mount within the coil spring, giving it a similar function as our 15° Flex Mount has. When used as a coil carrier it is recommended that a Cupped Foot and Domed Target (#25601) interface is used on the shaft end in order to provide location to the shaft end of the JounceShock in its "flexible" Coil Carrier Mount. The Domed Target is bolted or welded to the bottom spring seat.

**As a Bolt Up Mount:** It can be bolted or welded to the main structure of the vehicle. This method provides a fixed style mount where the cylinder end of the JounceShock threads into the mount and no articulation is allowed. To minimize side loading with a fixed style mount the JounceShock should be placed as close as possible to being perpendicular to the direction the suspension is traveling when the JounceShock is fully compressed. The mount plate can be trimmed in any fashion to accommodate specific applications and shapes. A minimum of three M10 class 10.9 (or 3/8 grade 8) bolts should be used. Typically this mount would be used with the Domed Foot (#25602) on the shaft end of the JounceShock and a Target Plate (#25608) or similar interface attached to the suspension.

**As a Weld Up Mount:** The zinc plating on the mount must be removed from the weld affected areas prior to welding to ensure a clean weld. The mount is made from carbon steel and proper welding practices should be followed to insure the structural integrity of the system. After welding, make sure to clean, mask, and paint the exposed edges of the mount in order to limit potential future corrosion.

**Use the 1/4"-20 Set Screw (provided) to keep the JounceShock from rotating. A small amount of thread locker should be use with this screw.**

*It is up to the installer/fabricator to ensure that the structure that the mount is bolted/welded to is strong enough to carry the loads of the JounceShock.*

For more information refer to the Technical Information section of our website [www.lightracing.com](http://www.lightracing.com).

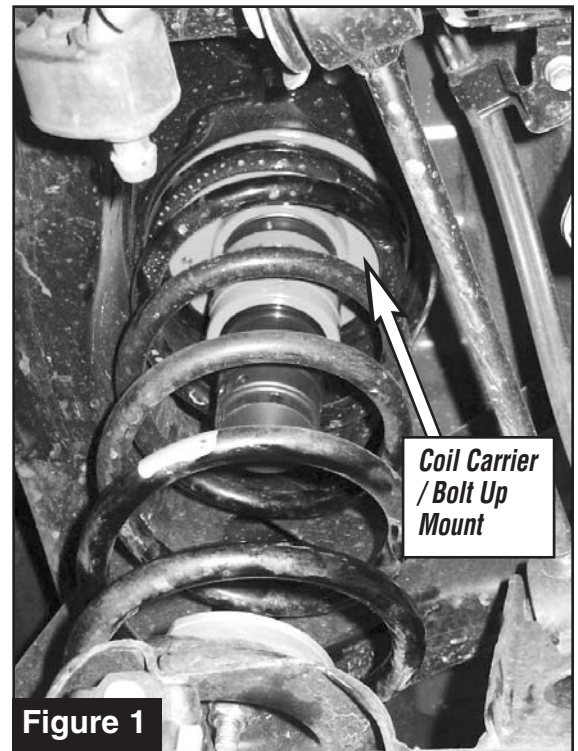
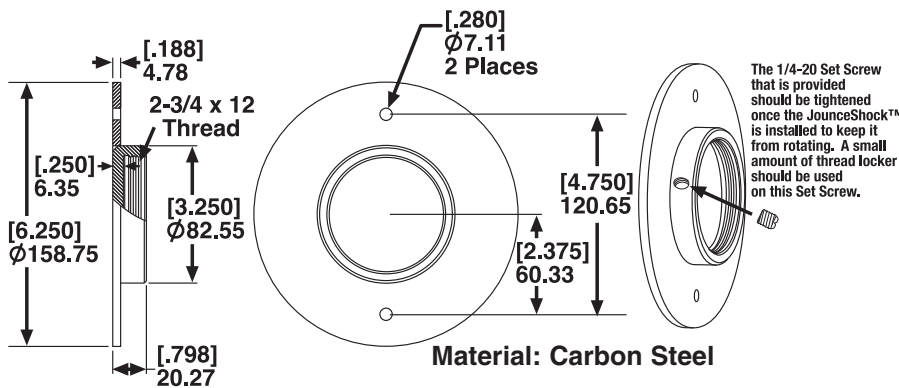

*There is no warranty stated or implied due to the inability to monitor the part's modification, installation, and use, except that Specialty Products Company warrants its products to be free from defects in material and workmanship for 90 days after purchase under normal use. In that case, parts returned must be determined by Specialty Products to be defective and Specialty Products's obligations under that warranty are solely limited to repairing or replacing, at its option, any part proven defective.*

*Final determination of the suitability of the parts for use contemplated by the buyer is the sole responsibility of the buyer. Specialty Products Company shall not be liable for any special, direct, indirect, incidental, or consequential damages that might be claimed as a result of the failure of any part, including claims for delay, loss of profits or labor. Specialty Products Company shall not be liable for any damage or injury to persons or property resulting from improper installation or misuse of any part subject to this warranty. There are no other warranties expressed or implied extending beyond those set forth above.*



**Specialty Products Company®**

P.O. Box 923 • Longmont, CO 80502 • (303) 772-2103 • Fax: (303) 772-1918 • [www.specprod.com](http://www.specprod.com) • [www.lightracing.com](http://www.lightracing.com) • Email: [info@specprod.com](mailto:info@specprod.com)

**Toll Free Technical Hot Line: 1-800-525-6505**

©2007 Niwot Corp. dba Specialty Products Co.® • Printed in U.S.A. • Form No. 985081 • Rev. 4/07