

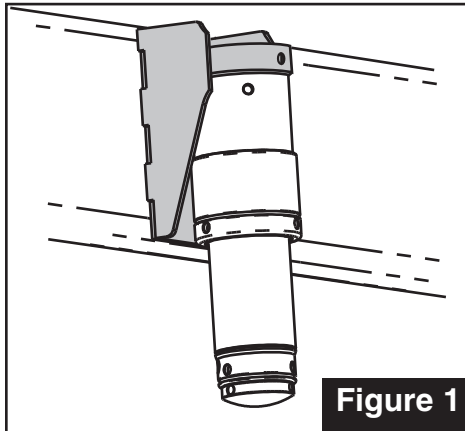

*This part should only be installed by personnel who have the necessary skill, training and tools to do the job correctly and safely. Incorrect installation can result in personal injury, vehicle damage and / or loss of vehicle control.*



**Figure 1**

### Read instructions completely before beginning installation.

The Frame Side Mount is a universal support bracket that can be trimmed to provide a range of heights with which to mount your JounceShock. This mount holds the JounceShock in a fixed position. It can be used as a weld on bracket or a bolt on bracket depending on your application.

The Frame Side Mount is intended to be used on the side of the vehicle frame or similar structure. After determining the location, the Mount can be trimmed according to whatever shape provides the best fit and support with the surrounding structure (frame). Welded into the Frame Side Mount is a threaded Fixed Mount (2-3/4 x 12 TPI internal thread) which accepts the JounceShock base unit.

### Using the Frame Side Mount:

The universal Frame Side Mount is most often used for solid axle applications. It can be mounted directly to the frame of the vehicle (**FIGURE 1**) and hold the JounceShock above the axle, ready to have the axle come up and hit the end of the JounceShock and compress it. Proper aiming or alignment is required to maximize the performance and durability of the system. In this application it is most common for the Domed Foot (#25602) to be threaded into the JounceShock and for the axle to have a flat Target Plate that contacts the Domed Foot surface. This allows for various angles of contact during suspension articulation. The flat Target Plate should be large enough to accommodate all possible articulation modes (a 3.25" x 2.5" Target Plate - #25608 can be purchased separately).

For more information on determining the placement of the JounceShock refer to the **Technical Information** section on our website [www.lightracing.com](http://www.lightracing.com).

### Installation Process:

1. Confirm that you have parts and tools required to complete job.
2. Determine optimum location and orientation for installation of JounceShock.
3. Confirm structural integrity of frame. Installer is responsible for structural integrity and load capacity of placement of Frame Side Mount. See our website or call technical support for tips and guidance.
4. Cut away excess Frame Side Mount material as required for placement. Mount may be cut down in a number of different ways to facilitate different mounting positions. Ensure that you leave enough material to provide a 5" spread between welds or bolts (in direction of load) as shown in **FIGURE 2**.
5. Bolt or weld the Frame Side Mount into place
  - a. Weld: If welding, powder coating and zinc plating on Mount must be removed from weld affected areas prior to welding to ensure weld integrity. Mount is made from mild steel and proper welding practices should be followed to insure structural integrity of the system.
  - b. Bolt: If bolting, a minimum of four M10 class 10.9 (or 3/8 grade 8) bolts should be used.
6. Paint exposed (cut, drilled, and/or welded) edges of Mount to limit corrosion.
7. Install JounceShock per instructions supplied with JounceShock (#25710 or #25715). Use the 1/4"-20 Set Screw (provided) to keep the JounceShock from rotating. A small amount of thread locker to use with this screw.

**Important:** The fully compressed JounceShock is designed to be the suspension travel stop. The stock rubber/urethane jounce bumper should be removed or cut down to a minimum height. This will eliminate the negative effect of stored energy that is released back into the suspension system by the stock jounce bumper.

See our [website www.lightracing.com](http://www.lightracing.com) for additional end mount and adapter options.

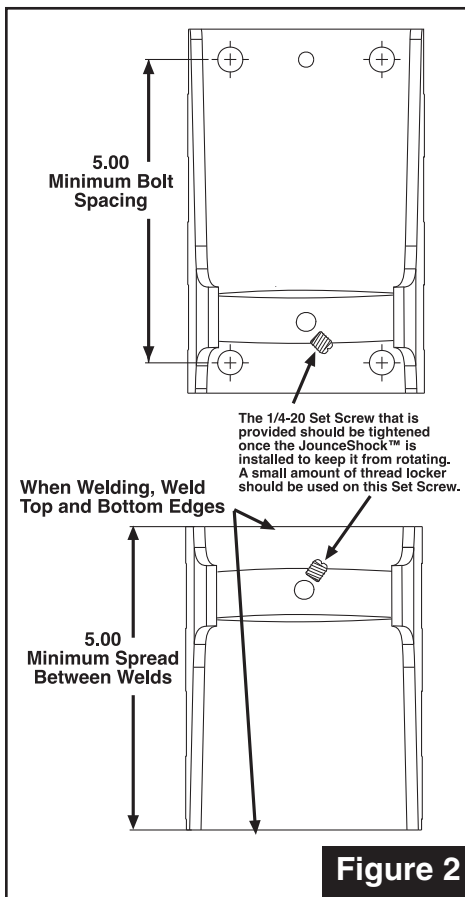

**Figure 2**

*There is no warranty stated or implied due to the inability to monitor the part's modification, installation, and use, except that Specialty Products Company warrants its products to be free from defects in material and workmanship for 90 days after purchase under normal use. In that case, parts returned must be determined by Specialty Products to be defective and Specialty Products's obligations under that warranty are solely limited to repairing or replacing, at its option, any part proven defective.*

*Final determination of the suitability of the parts for use contemplated by the buyer is the sole responsibility of the buyer. Specialty Products Company shall not be liable for any special, direct, indirect, incidental, or consequential damages that might be claimed as a result of the failure of any part, including claims for delay, loss of profits or labor. Specialty Products Company shall not be liable for any damage or injury to persons or property resulting from improper installation or misuse of any part subject to this warranty. There are no other warranties expressed or implied extending beyond those set forth above.*



## Specialty Products Company®

P.O. Box 923 • Longmont, CO 80502 • (303) 772-2103 • Fax: (303) 772-1918 • [www.specprod.com](http://www.specprod.com) • [www.lightracing.com](http://www.lightracing.com) • Email: [info@specprod.com](mailto:info@specprod.com)

**Toll Free Technical Hot Line: 1-800-525-6505**

©2007 Niwot Corp. dba Specialty Products Co.® • Printed in U.S.A. • Form No. 985301 • Rev. 4/07