

ITEM NO.	QTY	PART NUMBER	DESCRIPTION
1	1	256012	CUPPED FOOT
2	1	256011	PARTIAL SPHERICAL DOME
3	1	255011	FLEX MOUNT ASSEMBLY
4	1	257102	CJS, 1.5" TRAVEL

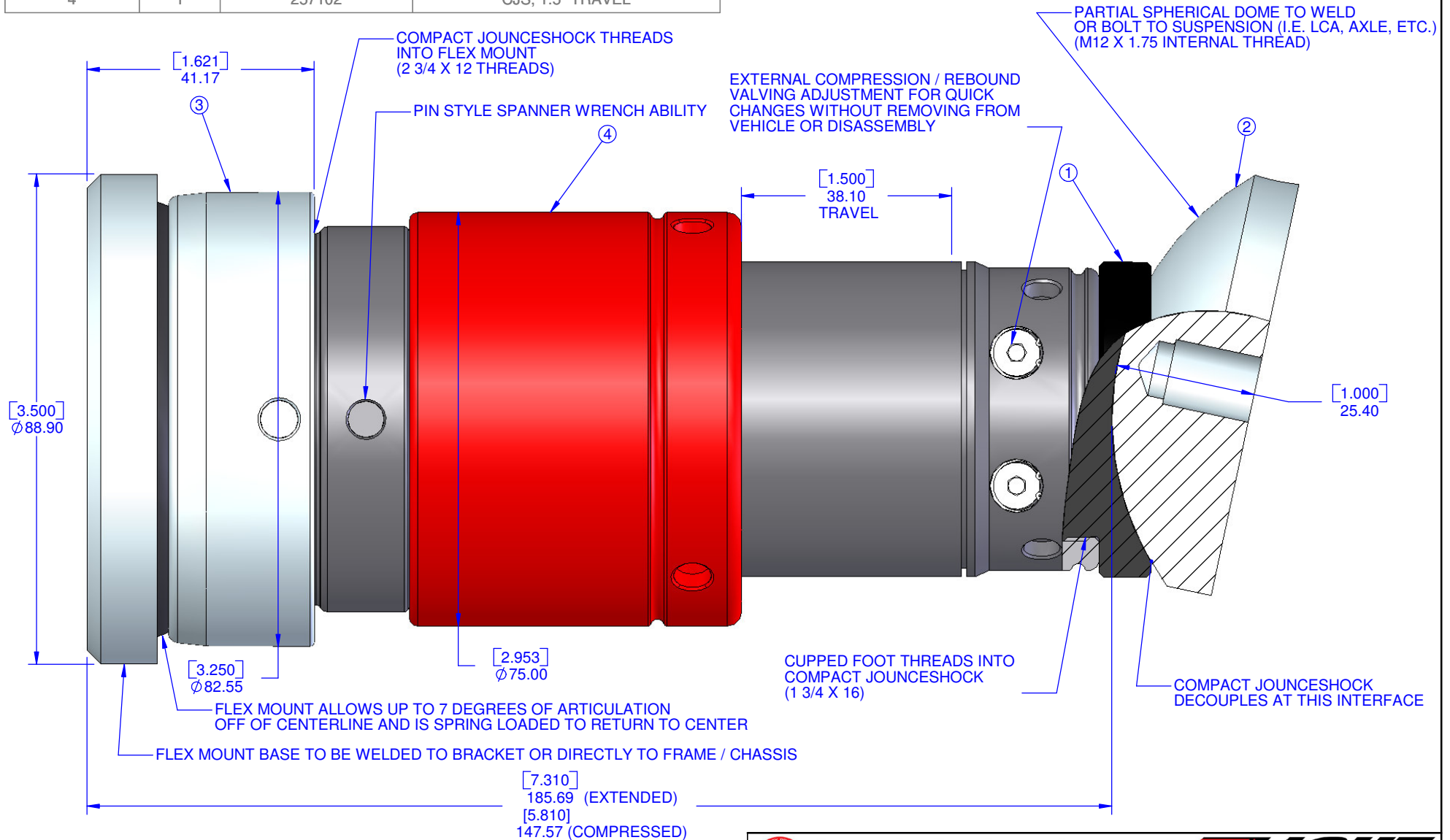

FOR ILLUSTRATIVE PURPOSES ONLY



**Specialty Products Company™**  
Longmont, CO 80504  
www.lightracing.com • 888-462-8054



COMPACT JOUNCESHOCK WITH FLEX MOUNT, CUPPED FOOT, AND DOME

DRAWN	CBL	CHECKED	MRL	DATE	5/15/06
SCALE	1:1	SIZE	A	DO NOT SCALE DRAWING	REV N/A SHEET 1 OF 1

THIS DOCUMENT CONTAINS PROPRIETARY INFORMATION WHICH SHALL NOT BE REPRODUCED, TRANSFERRED TO OTHER DOCUMENTS, DISCLOSED TO OTHERS, USED FOR MANUFACTURING OR ANY OTHER PURPOSE WITHOUT PRIOR WRITTEN PERMISSION FROM SPECIALTY PRODUCTS COMPANY.

UNLESS OTHERWISE SPECIFIED:  
DIMENSIONS AND TOLERANCES  
ARE IN MILLIMETERS  
AND DECIMAL DEGREES.  
CONFORMS TO ASME Y14.5M 1994

X ± 1.5,  
X.X ± 0.70,  
X.XX ± 0.25,  
ANGLES ± 2.0°